



RFSWLM-2420-131

S-Band Switch Limiter Module

Features:

- Surface Mount S- Band Switch Limiter Module – 5mm x 8mm x 2.5mm
- Frequency Range: 2 to 4 GHz
- Higher Average Power Handling than Plastic Packages - > 125W (CW)
- High Voltage Rating (>500V) Enabling Superior RF Peak Power Handling
- Low Insertion Loss (<0.85 dB)
- Low VSWR: 1.6 : 1
- Low Flat Leakage: < 13 dBm (typ)
- Low Spike Leakage: ~0.1 ergs (typ)
- Fast Recovery Time: < 700 nsec (typ)
- Operates from 5V, 30V, and -5V Supplies
- RoHS Compliant

Applications:

- Radar T/R Modules: S- Band
- Receiver Protectors: S-Band

Description:

The RFSWLM-2420-131 S-Band Switch Limiter Module is based on a proven hybrid assembly technique and incorporates a fully integrated DC biasing network for real estate sensitive designs. This design approach permits individual device selection enabling optimal RF performance versus other glass technology, monolithic approaches which suffer from both higher thermal resistance and RF performance compromises.

The RFSWLM-2420-131 S-Band Switch Limiter Module is manufactured using assembly techniques proven over decades of military and space applications. Additionally, customer specified testing conditions can be supported on various AQL testing regimes and individual production lot testing data is archived to permit perfect lot traceability.

The RFSWLM-2420-131 is designed to minimize the Antenna-Receiver Insertion Loss in the small signal receive state and to provide excellent input Return Loss in the Transmit-Antenna signal path under large signal (up to 51 dBm CW) conditions while in the transmit state.

The very low Thermal Resistance (<40°C/W) of the PIN diodes in the RFSWLM-2420-131 enable it to reliably handle RF incident power levels up to 51 dBm CW and RF Peak Incident Power of 53 dBm in

cold switching applications at $T_a = 85^\circ\text{C}$ -. The PIN Limiter Diode offer extremely low series resistance ($<1.5\Omega$) produces low Flat Leakage Power ($<15\text{ dBm}$) and its small capacitance ($<0.15\text{pF}$) produces very low Insertion Loss ($<0.85\text{ dB}$).

The RFSWLM-2420-131 is intended for use in high volume manufacturing and appropriate for use in solder reflow and aqua wash environments. The device is fully RoHS compliant.

Thermal Management Features

The RFSWLM-2420-131 based substrate has been design to offer superior long term reliability in the customer's application by utilizing ultra-thin Au plating to combat Au embrittlement concerns. Also, a proprietary design methodology has minimized the thermal resistance from the PIN Diode junction to base plate ($R_{\text{THJ-A}}$) to less than 20°C/W . This circuit topology couple with the thermal characteristic of the substrate design enables reliably handling High Input RF Power up to 51 dBm CW and RF Peak Power levels up to 53 dBm (25 uSec pulse width @ 5% duty cycle with base plate temperature at 85°C).

Environmental Capabilities

The RFSWLM-2420-131 is capable of meeting the environmental requirements of MIL-STD-202 and MIL-STD-750. The device employs a moisture seal enclosure and sealed plated through vias on the substrate carrier.

PIN Diodes are susceptible to ESD damage from an ESD event and are rated as Class 1A. The moisture sensitivity level rating is MSL 1.

RFSWLM-2420-131 S-Band Switch Limiter Schematic

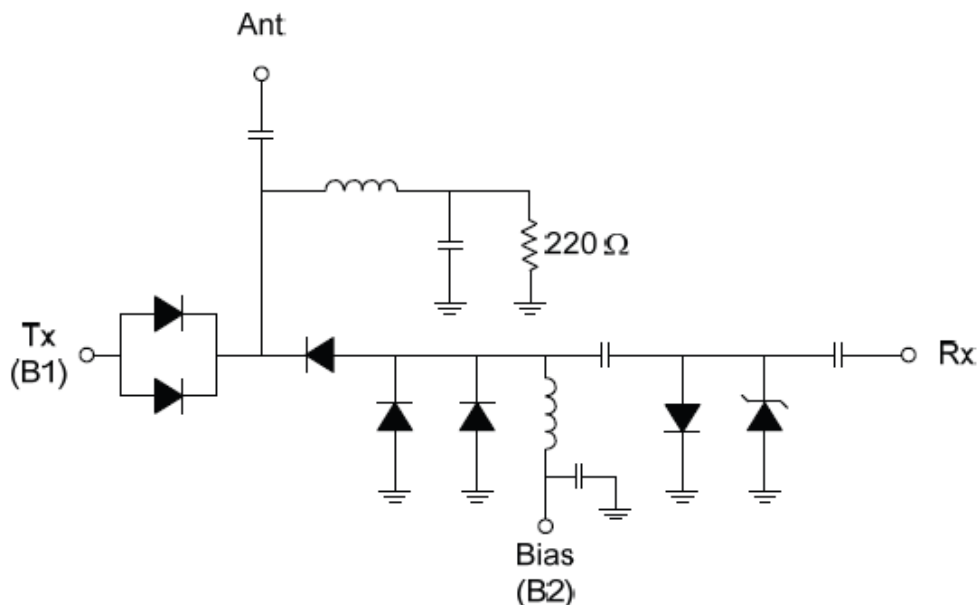

Truth Table

Antenna-Tx Path	Antenna – Rx Path	Transmit Port (B1)	Bias Port (B2)
Low Insertion Loss	Isolation State	30V @ 130 mA	-5V @ -25 mA
Isolation State	Low Insertion Loss	-5V @ 0 mA	5V @ 20 mA

RFSWLM-2420-131 Electrical Specifications from 2.0 to 4.0 GHz

@ $Z_0=50\Omega$, $T_A=+25^\circ\text{C}$ as measured on the base ground surface of the device.

Parameter	Symbol	Test Conditions	Min Value	Typ Value	Max Value	Units
Frequency	F		2.0	---	4.0	GHz
Ant-Tx Return Loss	RL (Tx)	Condition 1	12.0	20.0	---	dB
Ant-Rx Return Loss	RL (Rx)	Condition 2	13.0	15.0	---	dB
Ant-Tx Insertion Loss	IL (Tx)	Condition 1	---	0.25	0.35	dB
Ant-Rx Insertion Loss	IL (Rx)	Condition 2	---	0.7	1.7	dB
Ant-Rx Isolation	ISO (Rx)	Condition 1	35.0	40.0	---	
Tx Incident Power	P_{inc} (Tx CW)	Condition 1	---	---	51.0	dBm
Switching Time	T_{sw}	Condition 1,2,3 50% TTL To 90% RF Voltage	---	500	700	nsec
Ant-Rx Input Power	P_{inc} (Rx)	Condition 4	---	---	33.0	dBm
Flat Leakage Power	FL	Condition 3, $f = 2.5$ GHz	---	13.0	15.0	dBm
Spike Leakage Energy	SL	Condition 3	---	0.1	0.2	Ergs
Recovery Time	T_R	Condition 3, IL = 1 dB	---	700	1,000	nsec

RFSWLM-2420-131 Electrical Specifications from 3.1 to 3.5 GHz @ $T_a = +25^\circ\text{C}$

@ $Z_0=50\Omega$, $T_A=+25^\circ\text{C}$ as measured on the base ground surface of the device.

Parameter	Symbol	Test Conditions	Min Value	Typ Value	Max Value	Units
Frequency	F		3.1	---	3.5	GHz
Ant-Tx Return Loss	RL (Tx)	Condition 1	13.0	16.0	---	dB
Ant-Rx Return Loss	RL (Rx)	Condition 2	13.0	15.0	---	dB
Ant-Tx Insertion Loss	IL (Tx)	Condition 1	---	0.25	0.35	dB
Ant-Rx Insertion Loss	IL (Rx)	Condition 2	---	0.85	1.00	dB
Ant-Rx Isolation	ISO (Rx)	Condition 1	40.0	45.0	---	
Tx Incident Power	P_{inc} (Tx CW)	Condition 1	---	---	51.0	dBm
Switching Time	T_{sw}	Condition 1,2,3 50% TTL To 90% RF Voltage	---	500	700	nsec
Ant-Rx Input Power	P_{inc} (Rx)	Condition 4	---	---	33.0	dBm
Flat Leakage Power	FL	Condition 3, $f = 2.5$ GHz	---	13.0	15.0	dBm
Spike Leakage Energy	SL	Condition 3	---	0.1	0.2	Ergs
Recovery Time	T_R	Condition 3, IL = 1 dB	---	700	1,000	nsec

RFSWLM-2420-131 Electrical Specifications from 3.1 to 3.5 GHz @ Ta = +85°C

@ Zo=50Ω, TA= +85°C as measured on the base ground surface of the device.

Parameter	Symbol	Test Conditions	Min Value	Typ Value	Max Value	Units
Frequency	F		3.1	---	3.5	GHz
Ant-Tx Return Loss	RL (Tx)	Condition 1	13.0	16.0	---	dB
Ant-Rx Return Loss	RL (Rx)	Condition 2	13.0	15.0	---	dB
Ant-Tx Insertion Loss	IL (Tx)	Condition 1	---	0.35	0.40	dB
Ant-Rx Insertion Loss	IL (Rx)	Condition 2	---	1.00	1.20	dB
Ant-Rx Isolation	ISO (Rx)	Condition 1	40.0	43.0	---	
Tx Incident Power	P _{inc} (Tx CW)	Condition 1	---	---	51.0	dBm
Switching Time	T _{sw}	Condition 1,2,3 50% TTL To 90% RF Voltage	---	500	700	nsec
Ant-Rx Input Power	P _{inc} (Rx)	Condition 4	---	---	33.0	dBm
Flat Leakage Power	FL	Condition 3, f = 2.5 GHz	---	13.0	15.0	dBm
Spike Leakage Energy	SL	Condition 3	---	0.1	0.2	Ergs
Recovery Time	T _R	Condition 3, IL = 1 dB	---	700	1,000	nsec

Conditions:

1. Tx-Ant High Power Transmit State
 - a. Input signal: 125W @ 300 usec pulse width and 10% duty cycle, or 100 usec pulse width and 20% duty cycle.
 - b. Source/Load VSWR ≤ 1.2:1
 - c. DC Bias: 30 V @ approximately 130 mA applied to B1 and -1V @ approximately -25 mA to B2.
2. Ant-Rx Small Signal Receive State
 - a. Input Signal: -10 dBm
 - b. Source/Load VSWR ≤ 1.2:1
 - c. DC Bias: -5V @ 0 mA to B1, 4.7V @ approximately 20 mA to B2
3. Ant-Rx Large Signal Receiver Protect State
 - a. Input Signal: 33 dBm CW
 - b. Source/Load VSWR ≤ 1.2:1
 - c. DC Bias: -5V @ 0 mA to B1, 4.7V @ approximately 20 mA to B2
4. Ant-Tx Moderate Power Receiver Protection State
 - a. Source/Load VSWR = 1.2:1
 - b. Input signals: unsynchronized, 33 dBm CW
 - c. DC Bias: OFF

Typical Performance

$Z^0 = 50\Omega$, $T_A = +25^\circ\text{C}$

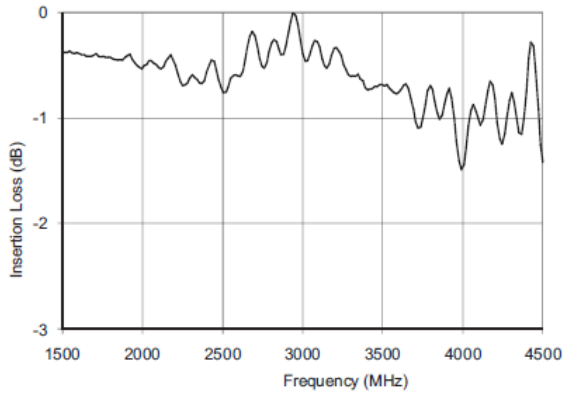

Insertion Loss, ANT-to-RX, $P_{IN} = -10\text{ dBm}$, Condition 2

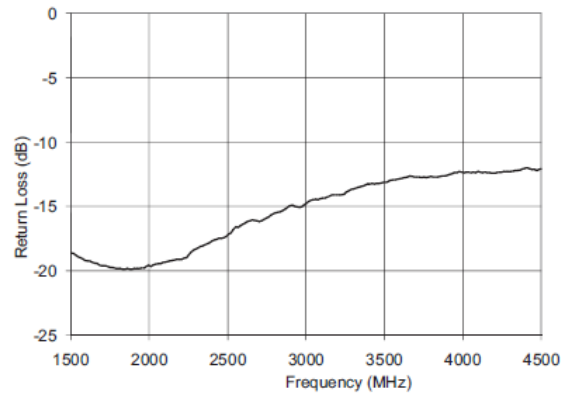

Return Loss, ANT-to-RX, $P_{IN} = -10\text{ dBm}$, Condition 2

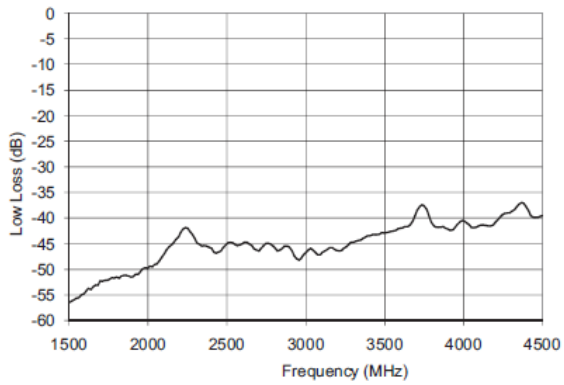

Isolation, ANT-to-RX, $P_{IN} = -10\text{ dBm}$, Condition 1

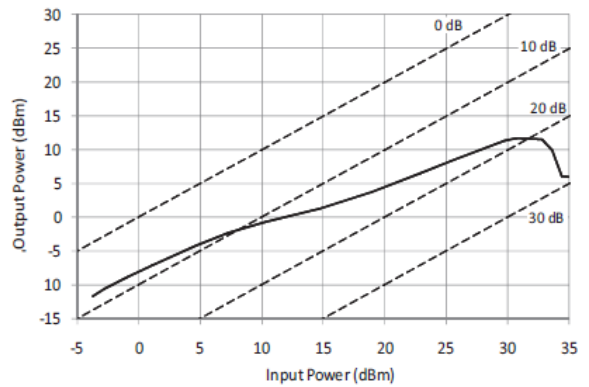

Output Power vs. Input Power, ANT to RX,
Condition 2, $f = 3.1\text{ GHz}$

Typical Performance

Zo= 50Ω, TA = +25oC

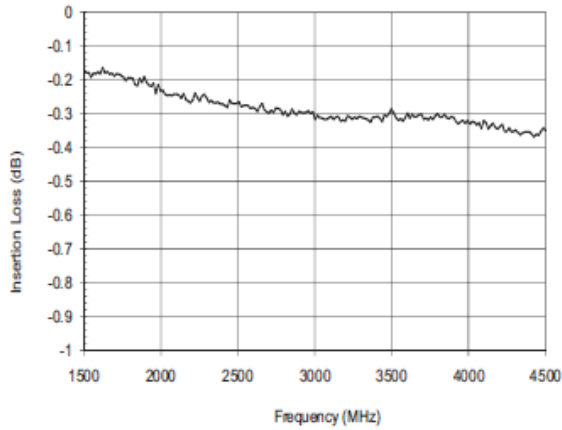

Insertion Loss, TX-to-ANT, P_{IN} = -10 dBm, Condition 1

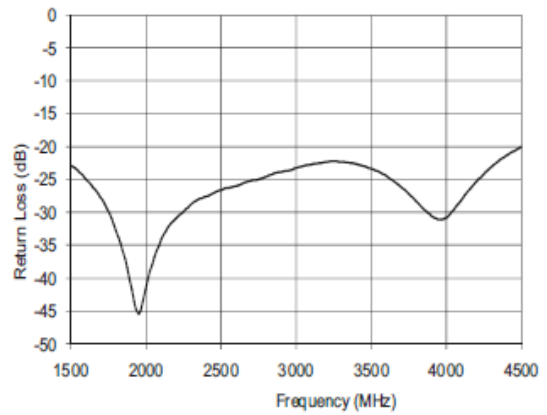

Return Loss, TX-to-ANT, P_{IN} = -10 dBm, Condition 1

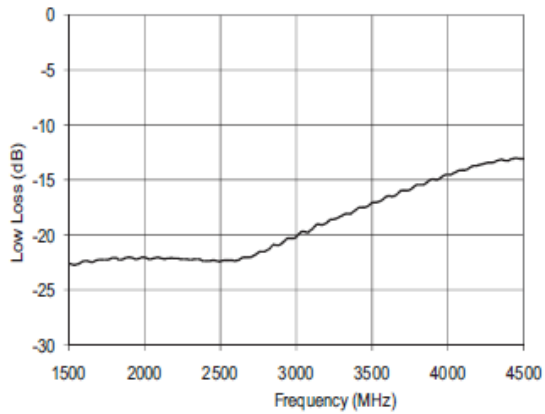

Isolation, TX-to-ANT, P_{IN} = -10 dBm, Condition 2

RFSWLM-2420-131 S-Band Switch Limiter Application

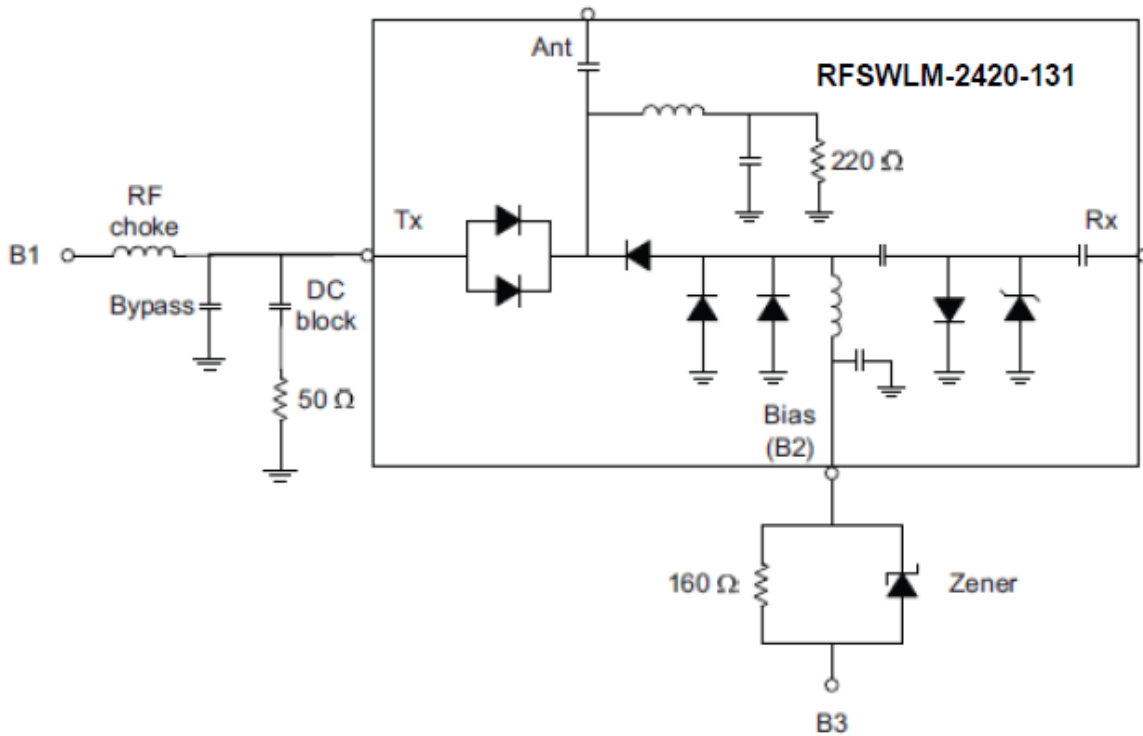

Truth Table

Ant-Tx Path	Ant-Rx Path	B1 Bias	B2 Bias	B3 Bias
Low Insertion Loss	Isolation	30V @ 130 mA	-1V @ -25 mA	-5V @ -25 mA
Isolation	Low Insertion Loss, Small RF input signal	-5V @ 0 mA	4.7V @ 20 mA	5.0V @ 20 mA

RFSWLM-2420-131 S-Band Switch Theory of Operations

The RFSWLM-2420-131 Switch Limiter shown in the above application schematic performs both passive and active receiver protection.

The Passive Protection State exists when Bias Ports B1, B2 & B3 are in the Isolation state shown in the above Truth Table. In the Passive Protection mode, any large signal presented at the antenna will activate the passive limiter circuit consisting of the limiter PIN diodes and the Schottky diode located at the RX output port. In this state the passive limiter circuit produces an impedance mismatch at the Ant-Rx signal path which reflects the large incident signal back towards its source.

The Active Protection State exists when Bias Ports B1, B2 & B3 are in the Low Insertion Loss state. In the Active Protection State, any large signal directed into the antenna port is routed to the off board 50Ω termination.

Absolute Maximum Ratings

TA=+25°C, Zo= 50Ω

Parameter	Absolute Maximum Value
DC Forward Current at Port B1	150mA
DC Reverse Voltage at Port B1	-40V
DC Forward Diode Voltage @ Port B1 or Port B2	1.2V @ 150 mA
Operating Temperature	-55°C to +85°C
Storage Temperature	-65°C to +150°C
Junction Temperature	+175°C
Assembly Temperature	+260°C for 10 seconds
Peak Incident Power Handling, 300 usec pulse width, 10% duty cycle, or 100 usec pulse width, 20% duty cycle, source and load VSWR = 1.2:1 (max)	51 dBm @ T _{CASE} = +85°C
Thermal Resistance: Junction to Package Terminals	45°C/W
Total Dissipated Power	10W @ T _{CASE} = +85°C

Assembly Instructions

The RFSWLM-2420-131 Switch Limiter Modules is available in either tube or Tape & Reel format. The RFSWLM-2420-131 may be attached to the printed circuit card using solder reflow procedures using either RoHS or Sn63/ Pb37 type solders per the Table and Temperature Profile Graph shown below:

Profile Parameter	Sn-Pb Assembly Technique	RoHS Assembly Technique
Average ramp-up rate (T _L to T _P)	3°C/sec (max)	3°C/sec (max)
Preheat		
Temp Min (T _{smin})	100°C	100°C
Temp Max (T _{smax})	150°C	150°C
Time (min to max) (t _s)	60 – 120 sec	60 – 180 sec
T _{smax} to T _L		
Ramp up Rate		3°C/sec (max)
Peak Temp (T _P)	225°C +0°C / -5°C	245°C +0°C / -5°C
Time within 5°C of Actual Peak Temp (T _P)	10 to 30 sec	20 to 40 sec
Time Maintained Above:		
Temp (T _L)	183°C	217°C
Time (t _L)	60 to 150 sec	60 to 150 sec
Ramp Down Rate	6°C/sec (max)	6°C/sec (max)
Time 25°C to T _P	6 minutes (max)	8 minutes (max)

Solder Re-Flow Time-Temperature Profile

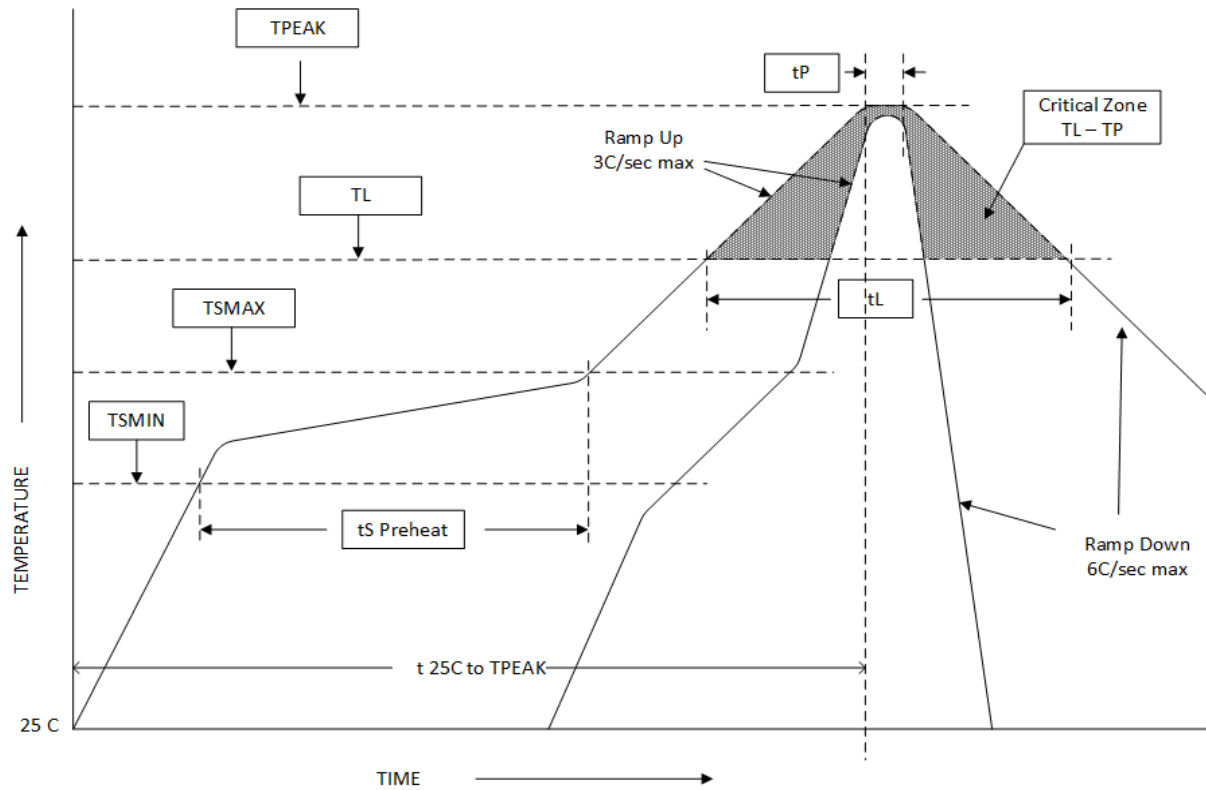

Notes:

- 1) Metalized area on backside is the RF, DC and Thermal ground. In user's end application this surface temperature must be managed to meet the power handling requirements.
- 2) Back side metallization is thin Au termination plating to combat Au embrittlement (15 u in typ Au plated over Ti-Pd).

Thermal Design Considerations:

The design of the RFSWLM-2420-131 Switch Limiter Modules permits the maximum efficiency in thermal management of the PIN Diodes while maintaining extremely high reliability. Optimum Limiter performance and reliability of the device can be achieved by the maintaining the base ground surface temperature of less than 85°C.

RFSWLM-2420-131 S-Band Switch Limiter Package Outline Drawing

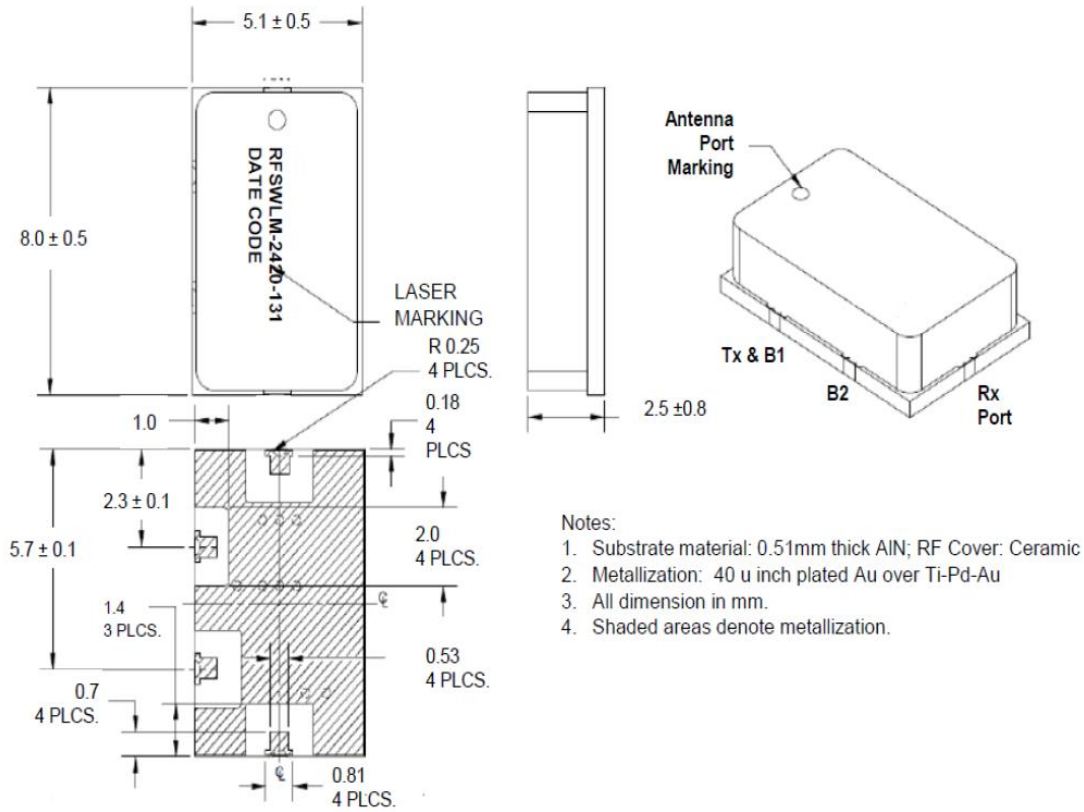

Recommended RF Circuit Solder Footprint for the RFSWLM-2420-131

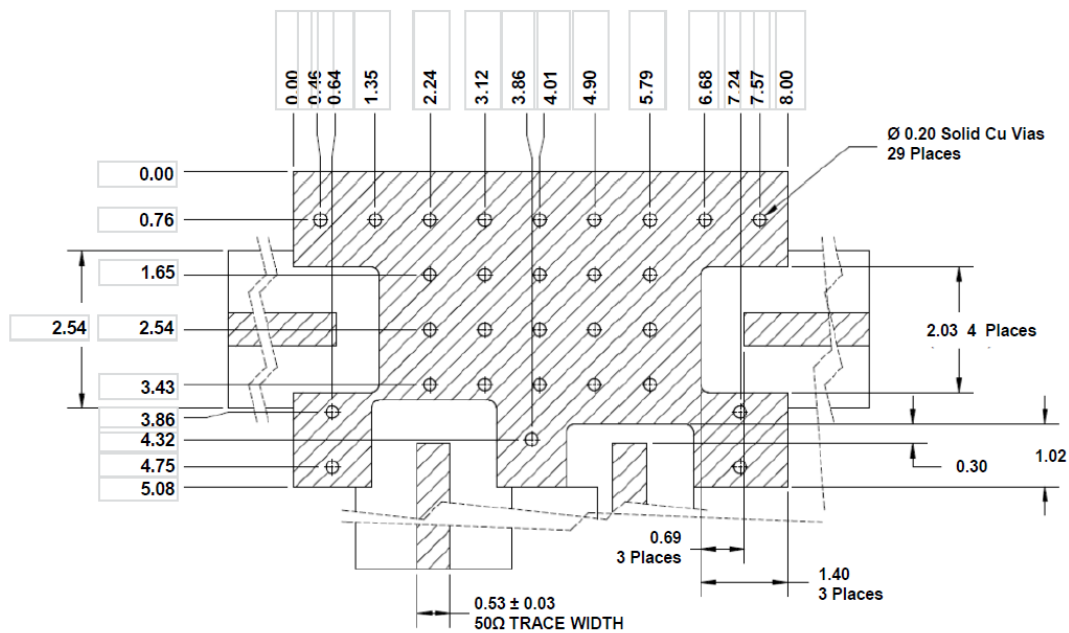

Note: All dimension in mm.

Notes:

- 1) Recommended PCB material is rogers 4350, 10 mils thick.
- 2) Hatched area is RF, DC and Thermal Ground. Vias should be solid Cu filled and Au plated for optimal heat transfer from backside of Limiter Module through circuit vias to thermal ground.

Part Number Ordering Detail:

Part Number	Packaging
RFSWLM-2420-131	Tube
RFSWLM2420-131TR	Tape & Reel (500 pcs)